

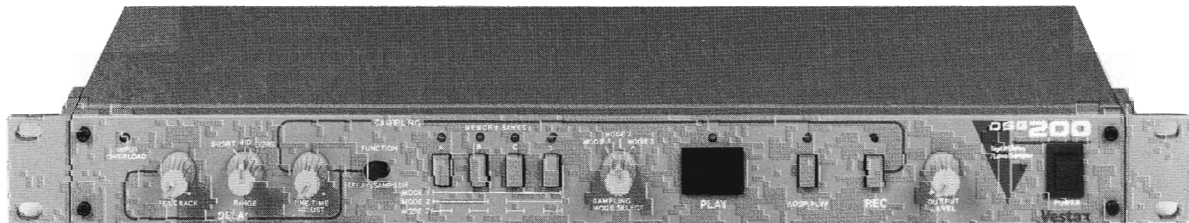

DIGITAL DELAY/LOOP SAMPLER GEAR

DSG-200

OWNER'S MANUAL



VESTAX CORP.

2-37-1 Kamiyama, Setagaya-ku, Tokyo 154
Phone : 03-3412-7011 Fax : 03-3412-7013

VESTAX MUSICAL ELECTRONICS CORP.

2860 Cordelia Rd. Suite 120 Fairfield, CA 94585 U.S.A.
Phone : 707-427-1920 Fax : 707-427-2023

VESTAX (Europe) Ltd.,

19 Haslemere Road, Fernhurst, Haslemere, Surrey GU 27 3EA England.
Phone : 0428-653117 Fax : 0428-61021

IMPORTANT

To prevent electric shock, do not remove cover. No user serviceable parts inside, refer servicing to qualified personnel. Always disconnect all the equipment from the main supply when disconnecting the signal leads. Disconnect from AC supply when equipment is not used for an extended period of time.

PRECAUTIONS

Please read these instructions before operating this unit.

*Humidity and Dust

Avoid use where there is high humidity and dust which may cause damage to internal parts.

*Temperature

Avoid use in hot (over 35°C) and cold (below 5°C) locations. Keep the unit away from extreme heat, such as direct sunlight, heating radiators, or closed vehicles.

*Keep away from liquids.

Do not stand vessels containing liquids on or near the equipment. If liquid does happen to enter equipment, disconnect the power cord from the power cord from the outlet immediately.

WARRANTY

Warranty might vary from country to country. Each distributor has own warranty system in accordance with country or state regulations. VESTAX has manufacturer's responsibility for products by the manufacturing country's regulations.

FEATURES

*Superd quality 8 seconds sampling capability.

*Four 2 second memories, two 4 second memories or one 8 second memory.

*Separate 2 second controllable digital delay. Can be used without losing recorded samples.

*MIX/LEVEL control provides sample playback volume of samples.

*Easy to add to existing equipment.

*Fast table top finger action.

※To connect with foot switch, the operation of play back (sampler) can be done by pressing with the foot.

SPECIFICATIONS

INPUT LEVEL/IMPEDANCE	: -10dBV/50K Ω	1/4inch phone jack \times 2
OUTPUT LEVEL/LOAD IMPEDANCE	: -10dBV/10K Ω	1/4inch phone jack \times 2
AD/DA CONVERSION	: ADM	
FREQUENCY RESPONSE	: 20Hz~15KHz (MULTI: MIN)	
S/N RATIO	: 75dB (IHF-A WTD)	
SAMPLING TIME (MULTI TIME ADJUST: MAX)	: 2 seconds [4 bank mode]	
	: 4 seconds [2 bank mode]	
	: 8 seconds [1 bank mode]	
DELAY TIME	: 128mS ~ 512mS [Short Range]	
	: 258mS ~ 1024mS [Mid Range]	
	: 518mS ~ 2048mS [Long Range]	
POWER	: AC ADAPTOR DC-15 (15volt DC, 400mA)	
DEMENSIONS (W \times H \times D)	: 482 \times 44 \times 158mm	

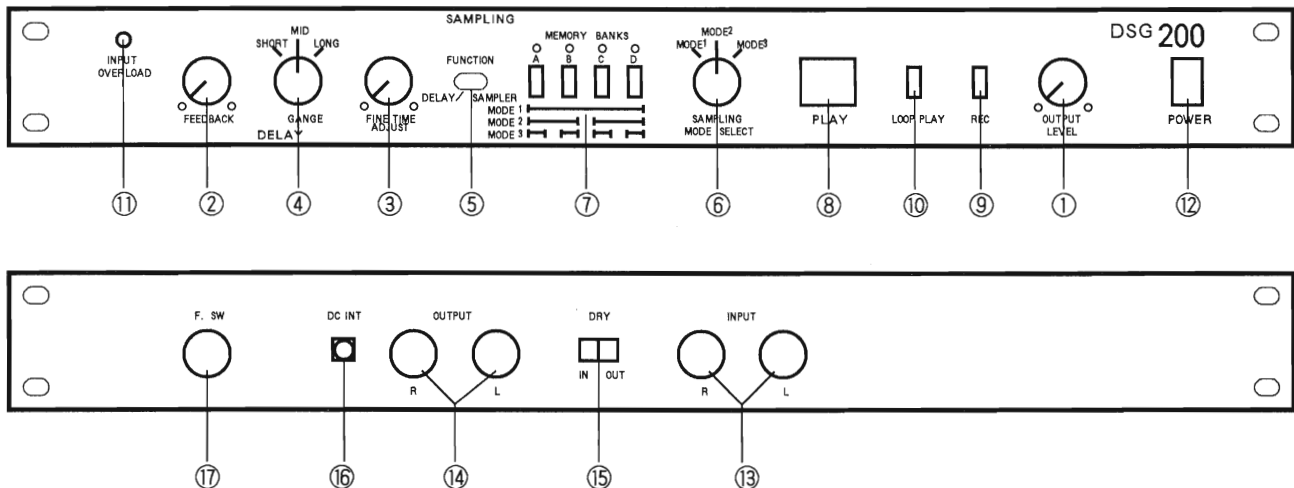

TOP PANEL

- ① **OUTPUT LEVEL**
Decides level of delay and sampler playback.
- ② **FEEDBACK**
When the Digital Delay circuitry is set to Delay, this control determines the number of repeats. One repeat will be obtained with the control set to the left.
Note : This is automatically cancelled when Sampling is selected.
- ③ **FINE TIME ADJUST**
Adjusts sampling time and delay time.
- ④ **RANGE**
Sets range of adjustment for delay time.
course :
Short 128 ~ 512 mS
Mid 256 ~ 1024 mS
Long 512 ~ 2048 mS
Note : This is automatically cancelled when sampling is selected.
- ⑤ **FUNCTION**
Selects Digital Delay or Digital Sampler.
- ⑥ **SAMPLING MODE SELECTOR**
Selects Sampling time.
MODE 1:1 bank maximum Sampling time 8 seconds.
MODE 2:2 banks maximum Sampling time 4 seconds each.
MODE 3:4 banks maximum Sampling time 2 seconds each.
- ⑦ **BANK SWITCHS A, B, C, D/BANK INDICATOR**
Selects Sampling banks. An indicator lamp shows selection.
Use these with Sampling Mode Delactor.
MODE 1:1 bank, use bank A (8 seconds)
MODE 2:2 banks, use bank A, B, C (2×4 seconds)
MODE 3:4 banks, use bank A, B, C & D (4×2 seconds)
- ⑧ **PLAY SWITCH**
Playback automatically stops when the sampled sound comes to an end, or when the button is released.

⑨ REC SWITCH

In sampling mode this switch initiates sampling (recording). Sampling will automatically stop when selected time ends.

⑩ LOOP PLAY SW. INDICATOR :

When this switch is pressed the sampled sound which has been assigned is played back repeatedly. The indicator of the bank selected for playing flashes to show which bank the sound is sampled to.

Also, when in mode 1 and 2, it indicates the order of play back, and can therefore be used as a basis for timing of sampling.

⑪ OVER LOAD

This indicator illuminates during signal clipping. Turn the output level down from the external mixer until it extinguishes.

⑫ POWER SWITCH

*30 seconds after the switch is turned off, the output is muted to clear the memory and the bank LED will flash accordingly.

REAR PANEL

- ⑬ **INPUT JACK (¼ inch jack)**
Connect the mixer, Cassette deck, CD player, etc to line input.
Connect AUX SEND jack of the mixer.
- ⑭ **OUTPUT JACK (¼ inch jack)**
-10dBV output jacks for connection to pre-amps, poweramps, or AUX RETURN jack of the mixer.
- ⑮ **DRY IN/CUT SWITCH**
Selects DRY sound or DRY + DELAY/SAMPLE sound. When the AUX SEND/RETURN jacks of mixer are connected to the DSG-200, Select DRY-CUT position.
- ⑯ **DC-IN**
- ⑰ **F-SW JACK (¼ inch jack)**
When connected to a foot switch, playback can be operated by pressing with the foot.

CONNECTION

